

The Complete Consumer Unit

Issue 4

Get to know us

Elucian by Click® brings to market a comprehensive Consumer Unit and Circuit Protection range.

Following months of extensive research and consultation with contractors and installers, we developed a range of products that best suits their requirements and that are compliant with all the latest regulations.

Designed with the installer in mind, Elucian is an extensive range of metal consumer units that will cover a broad range of installations and offers a number of features and benefits that will enhance the products' convenience, flexibility and safety properties.

 elucian



Welcomes



Keeping Up with Regulations...

The Elucian consumer units range has been designed to ensure compliance with BS 7671. Our engineers have considered how installers need to comply with the UK wiring regulations when installing consumer units in properties across the UK. The Elucian range has comprehensive options for every installation. These consist of Main Switch units, RCBO units, Split Load units and our Combination units.

Overload Protection (536.4.3.2) & (536.4.202)

RCCBs are not designed to be able to withstand overload current. Care should be given when assessing the likely loading of the final circuits.

The designer and installer must therefore select the correct rated device from the options we have made available; 63A, 80A or 100A. To make this process easier we have installed 80A devices as standard.

Overvoltage Protection (Section 443) & (Section 553)

SPDs offer very effective protection against overvoltage. Section 443 covers the requirements for consideration when selecting SPDs in the electrical system.

Section 553 confirms what SPDs are required and where they must be installed within the electrical system.

We have designed our SPD consumer unit to incorporate a type 2 device. These devices offer protection from man-made overvoltages or lightning strokes within the vicinity of the installation.

Having SPDs installed adjacent to the main switch allows for compliance with the maximum cable length from the SPD to Earth.

Types of RCD (531.3.3)

Many different types of RCD exist. BS 7671 recognises types AC, A, F and B. Currently AC RCDs are recognised as acceptable for general purpose. However, if the installation has any DC components or frequency alterations due to connected loads one of the other types must be selected.

As most installations in the UK now have some DC components, it would be prudent to select a type A RCD that has the ability to work with DC fault current. We have produced type A RCDs only as they comply with the requirements of the AC type, they include added benefits of the DC threshold.

Division of Installation (Section 314)

This regulation set requires the designer and installer to ensure the installation is divided up as necessary to:

- (i) Avoid danger and minimise inconvenience in the event of a fault.
- (ii) Facilitate safe inspection, testing and maintenance.
- (iii) Take account of hazards that may arise from the failure of a single circuit such as a lighting circuit.
- (iv) Reduce the possibility of unwanted tripping of RCDs due to excessive protective conductor current or due to fault.
- (v) Mitigate the effects of electromagnetic disturbances.
- (vi) Prevent the indirect energization of a circuit intended to be isolated.

Overload Protection of RCDs...

These devices may be overloaded if the combined outgoing current from the final circuits is greater than the rating of the RCCB. Therefore, we provide an 80A device as standard with the ability to change this to a 100A, or reduce to a 63A if required.



(536.4.3.2)

"RCCBs & switches do not provide protection against overload, therefore they shall be protected by an overcurrent protective device."

(536.4.202)

"... overload protection shall not solely be based on the use of diversity factors of the downstream circuits. To achieve overload protection of RCCBs or switches, the rated current of the over-current protective device (OCPD) shall be selected according to the manufacturers instructions".

Comply with the regs...

Regulations 536.4.3.2 and 536.4.202 require the designer to understand the loading profile of the RCCBs within the consumer unit. RCCBs will protect a number of outgoing circuits at the same time.

Method 1

Ensure the full load of all final circuits being protected are less than the rating of the RCCB. The installer will need to consider diversity for the final circuits but, not use diversity as the sole factor for calculating the total current downstream of the device.

Method 2

Ensure the main protective device is of a size to limit the total amount of amps upstream of the devices.

Example 1:

This install would not comply. RCCB1 could be subject to overload.

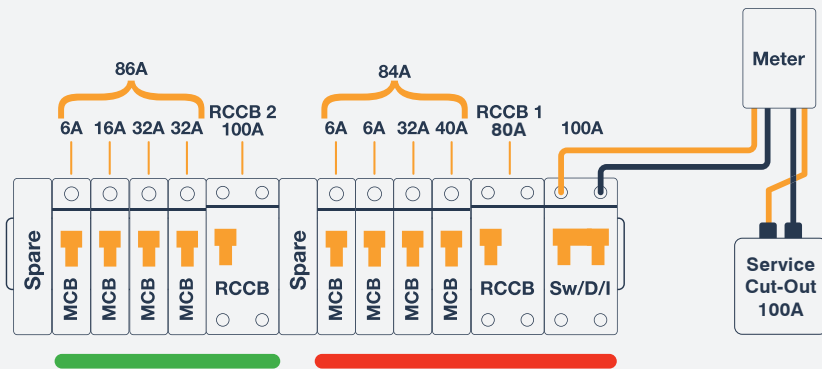

Example 2:

This installation would comply. Although RCCB1 could potentially become overloaded, the protective device at the origin would offer overload protection.

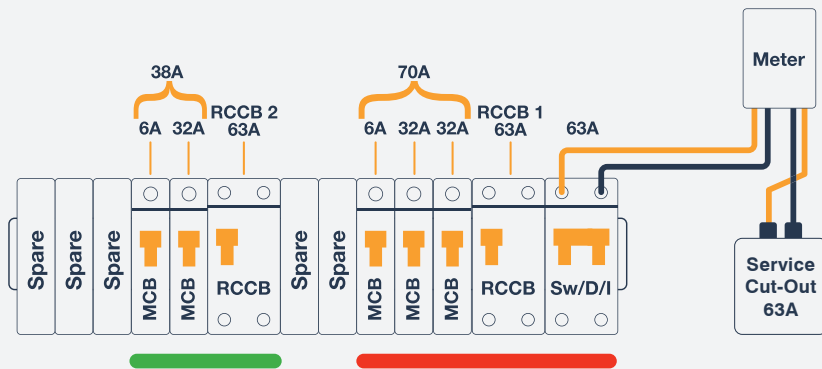

Example 3:

RCBOs offer comprehensive protection as each device is rated to the circuit.

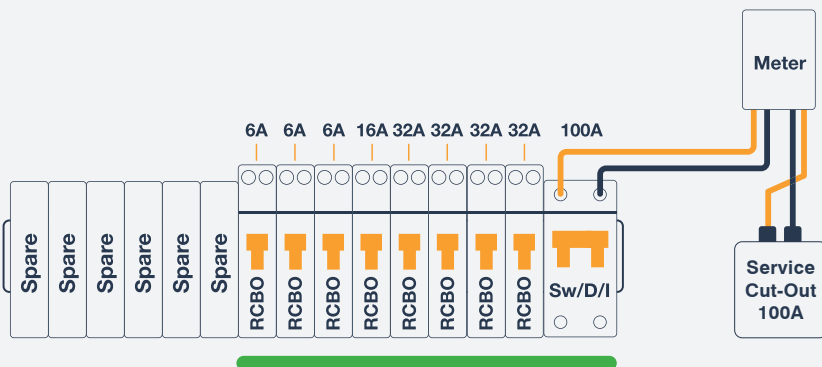



3YR

3 Year
Warranty

B

B Curve
Devices

C

C Curve
Devices

O

Large Terminal
Capacity

Enhanced Protection Against Arc Faults

The smart way to detect arc faults in your circuit. With the amendment 2 of the 18th Edition it is now required for AFDDs to be installed for circuits supplying socket outlets in 4 areas;

- High Risk Residential Buildings (18M or 6 Storeys +)
- Houses of Multiple Occupancy (HMO),
- Purpose Built Student Accommodation
- Care Homes

What can an AFDD Detect?

• A series arc fault

Is where the arc happens between two parts of the same conductor, such as a broken line conductor or a poorly terminated line conductor.

• A parallel arc fault

Is where the arc occurs between the line conductor and either the neutral or earth conductors. If an arc fault occurs between line and earth there is quite a high likelihood that the RCD part of the AFDD will also operate.

• Over Voltage Detection

This may indicate that the property has had a surge in voltage, if this continues you would need to contact the Electricity provider for your property.

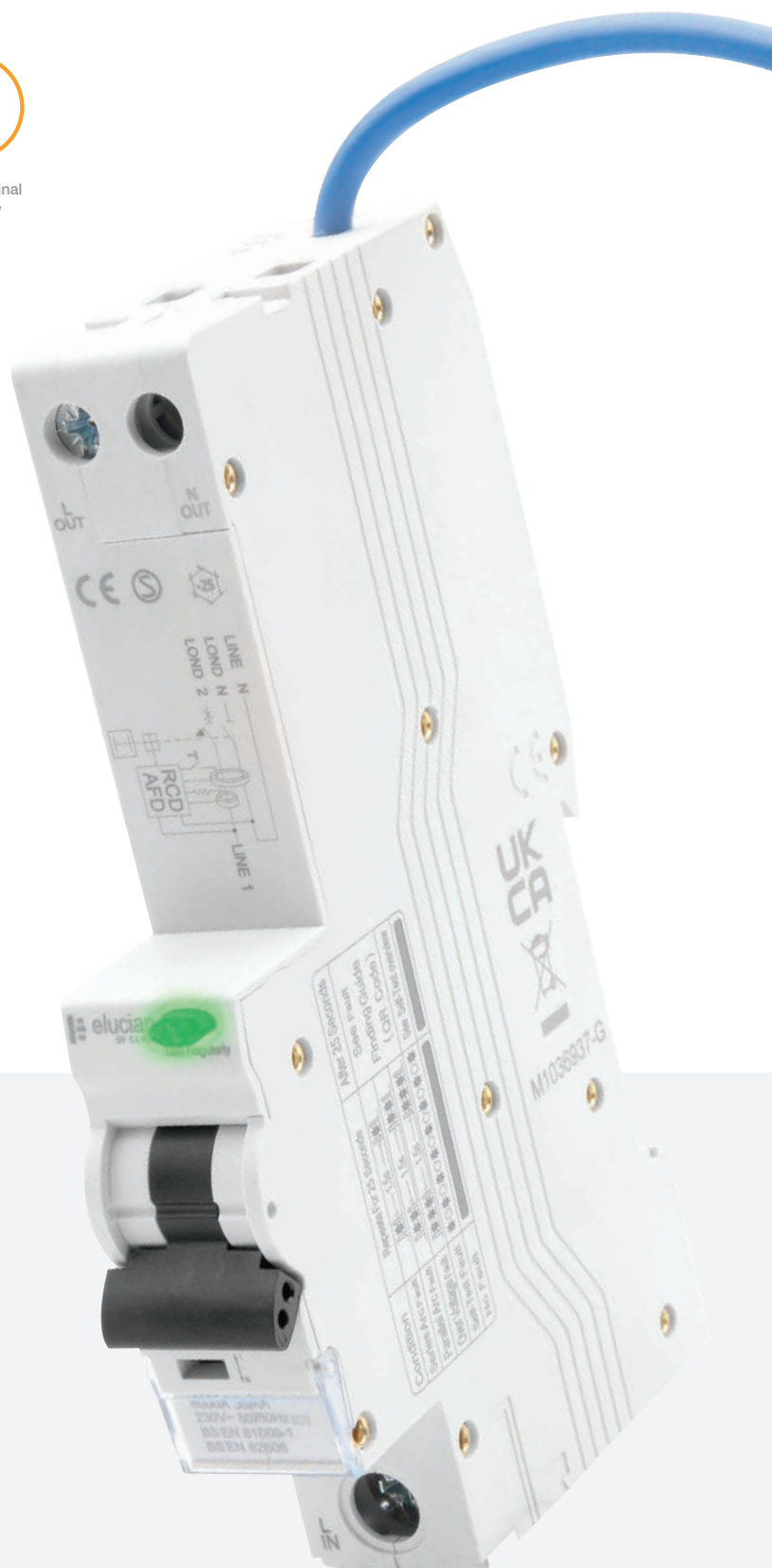

RCD & RCBO

Protective Devices...

RCDs are available in a number of common types; AC, A, F or B. Dependant on the characteristics of the final circuit/s being controlled, the type of RCD selected is very important. If it is believed DC current could be present in the protected circuit/s due to the equipment connected, the designer should select a device capable of working with that DC current present.

General RCDs are designed to operate instantaneously without intentional delay; because of this they are not designed to discriminate in the event of a fault. Therefore, if two general RCDs were to be installed in series, both may operate when a fault presents itself. To avoid this, selectivity is essential between the installed devices to reduce the unintentional operation of a device upstream from the leakage to Earth.

Installing the correct type of device is essential if it is believed DC fault current could be present within the installation. It is important to install an RCD type that is capable of handling DC fault current ahead of a device that isn't able to operate with these currents.

Such as:

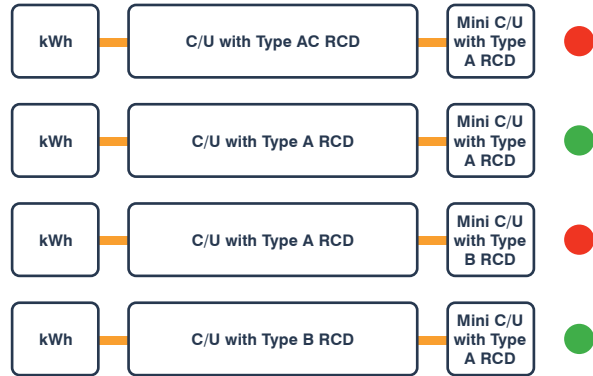

Type A RCD

In today's installations the majority of equipment does have some residual DC current due to the internal electronics. The magnitude of this current can have a detrimental effect on the effectiveness of the protective device. Therefore, we have taken the decision to manufacture Type A devices only.

Type A devices have the ability to continue to work with up to 6mA of DC fault current present. This amount of fault current has been shown to stop AC Type RCDs/RCBOs from working within the maximum time permitted in BS7671.

RCCB - Residual Current Operated Circuit Breaker, without integrated overcurrent protection.



RCBO Protection

These devices combine the functionality of an MCB and RCD into one single device/module. Available as a Type A RCD with different inrush curve types B or C, these protective devices have been miniaturised to maximise the available space above for termination or final circuits.

The Neutral fly lead has been made long enough to ensure safe connection to the dedicated Neutral bars.

RCBO - Residual Current Operated Circuit Breaker, with integrated overcurrent protection.



Surge Protection...

Transient Overvoltages

Many installations across the UK have electronic components within them. Surge protection will offer those devices and appliances protection from overvoltage.

Products such as computers, printers, flat screen televisions, alarms, microwaves and washing machines are commonplace. These can all be vulnerable to transient overvoltages, which can significantly reduce the equipment's lifespan through degradation and damage.

A transient overvoltage or surge is a short duration increase in voltage measured between two or more conductors. In short, this means anything from microseconds (millionths of a second) to a few milliseconds (thousandths of a second) in duration.



Regulation 443.4.1

'Regulation 443.4.1' requires protection against transient overvoltages to be provided where:

- Serious injury to, or loss of, human life may occur,
- Failure of a safety service (and this includes smoke and heat alarms)
- Significant financial or date loss.

In all other cases an SPD should be installed unless the owner of the installation declares it not required.



SPD Type 2

SPD which can prevent the spread of overvoltages in the electrical installation and protects equipment connected to it. It usually employs metal oxide varistor (MOV) technology and is characterised by an 8/20 μ s current wave.

Terminology

I_{imp} - Impulse current of 10/350 μ s waveform.

I_n - Surge current of 8/20 μ s waveform associated with Type 2 SPDs.

U_p - The residual voltage that is measured across the terminal of the SPD when I_n is applied.

U_c - The maximum voltage which may be continuously applied to the SPD without it conducting.

I_{max} - Maximum short circuit current of the device.



Consumer Units

Functional, stylish, and innovative, our Elucian range of consumer units provides an exceptional option for any residential or light commercial environment. Packed with features making installation quick and simple for electricians, with a clear labelling kit for easy identification for the customer. A great range of configurations and sizes makes Elucian perfect for any installation requirement.

 elucian



01

Features & Benefits...



Metal Consumer Units

All Elucian consumer units are constructed using non-combustible and robust metal housings. They ensure compliance against the third amendment which was added to the BS 7671 wiring regulations in 2015 requiring consumer units in domestic premises to have a non-combustible enclosure.

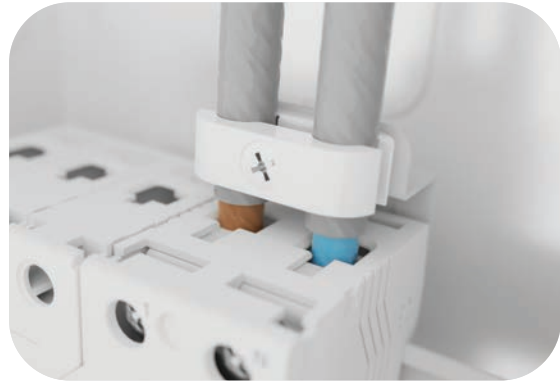

Mains Switch Tail Clamp

Each consumer and mini unit come supplied and pre-fitted with a Mains Switch Tail Clamp for added stress relief to ensure the Mains Tail terminations do not come loose and to help fix the Mains Switch Isolator more securely to prevent any rocking or movement. The Mains Switch Tail Clamp will accept a maximum of 25mm² double insulated tails.



Variable Knockout Sizes

The units all come supplied with a wide range of 40mm, 32mm, 25mm and 20mm knockouts making each board universally adaptable for all installation and cable types.



Rear Knockouts

The units also come supplied with rear knockouts to provide ample cabling capacity for any installation type. Each knockout will be supplied with a 0.5M grommet strip to allow a smooth entry into the board, protecting cable from any potential sharp edges.



Shrouded Live Bus Bar

Our live bus bar comes supplied with the shroud pre-fitted for extra safety and convenience. Our Neutral and Earth Bus Bars are supplied with backed off screws allowing a faster installation.



Accessories Pack

Contains a Sticker Set for clear circuit identification and caution warnings, Grommet Knockout Strips, 2 x Blank Modules, a detailed instruction sheet for all recommended installation details and a Live Bus Bar, Cover and Caps for added insulation and installation completion.

Consumer Unit Breakdown...

Torque Rating Label

There is a handy Torque rating label inside every consumer unit, allowing you to make all terminations with ease.

Grommet Strip

Each knockout will be supplied with a 0.5M grommet strip to allow a smooth entry into the board, protecting cable from any potential sharp edges.

Compact RCBOs

The latest design in compact RCBOs leaves more than sufficient space for cabling and terminating.

Keyway DIN Rail

A fast release Keyway DIN Rail allows for ease of installation.

MCB Style Solid Blanks

These are DIN Rail mountable and can only be removed when the cover is removed, thus providing additional safety. Other types of blanks can easily fall out or become dislodged.

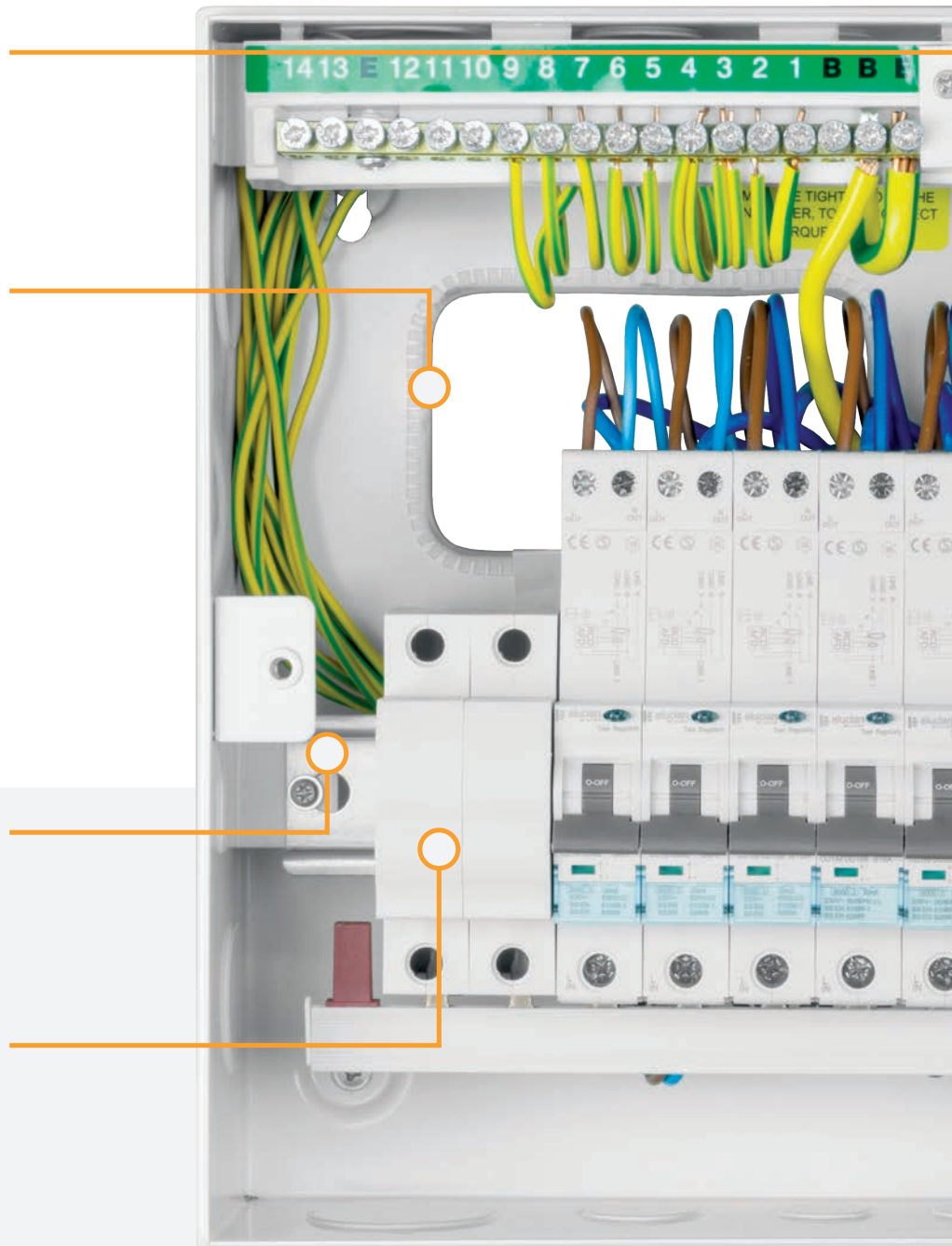

Large Space for Wiring

Each consumer unit has a large space for wiring, suitable for the increasing demands and circuit ways on a consumer unit.

Non-Combustible Enclosures

Non-combustible and robust metal housings ensure compliance against the third amendment added to the BS 7671 wiring regulations.

Earth and Neutral Bar

Each unit has its own specifically configured Earth and Neutral Bar to allow for best practice installation of each board type.

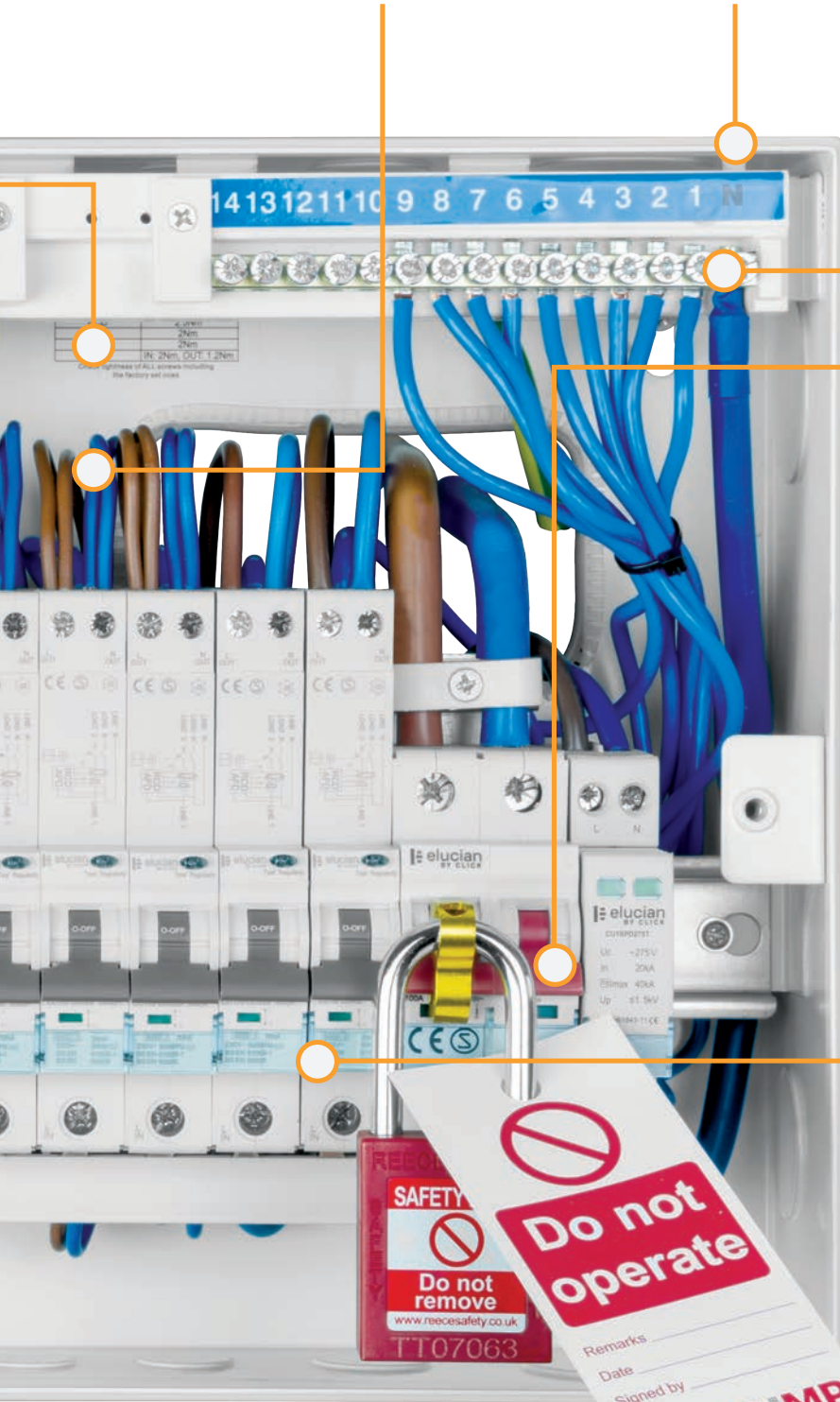

Lock Off Capabilities

Lockout devices are designed to attach to the moving part of the protective device, usually a switch toggle (rocker switch) which moves from the on to off position.

Enhanced Protection with AFDDs with integrated RCBO

The smart way to detect arc faults in your circuits.

Complete the Installation...

UNICRIMP[®]

The Unicrimp[®] range includes cable ties, crimp terminals, PVC tape, copper tube terminals, cable clips, brass/nylon glands, tail glands and earth sleeving – providing everything required to harness cable between the consumer unit and the end accessory.

Helps to provide compliance with Regulation 522.8.5.



OB1[™]

MULTI-SURFACE
CONSTRUCTION
SEALANT & ADHESIVE

The No.1 hybrid sealant and adhesive. OB1 bonds and seals a range of materials, works in damp conditions and even under water. User-friendly, hybrid polymer formulation for the ultimate in bonding and sealing.



Q-NECT

Focusing on strong, quick and reliable solutions, the new Q-Nect range offers great versatility for electrical connections. Each product is packed with features which makes your installations quicker and easier.



Q-FIRE

Don't get caught out by the latest regs! Explore our range of fire rated products and prevent cables from premature collapse during a fire and keep emergency services and the public safe.

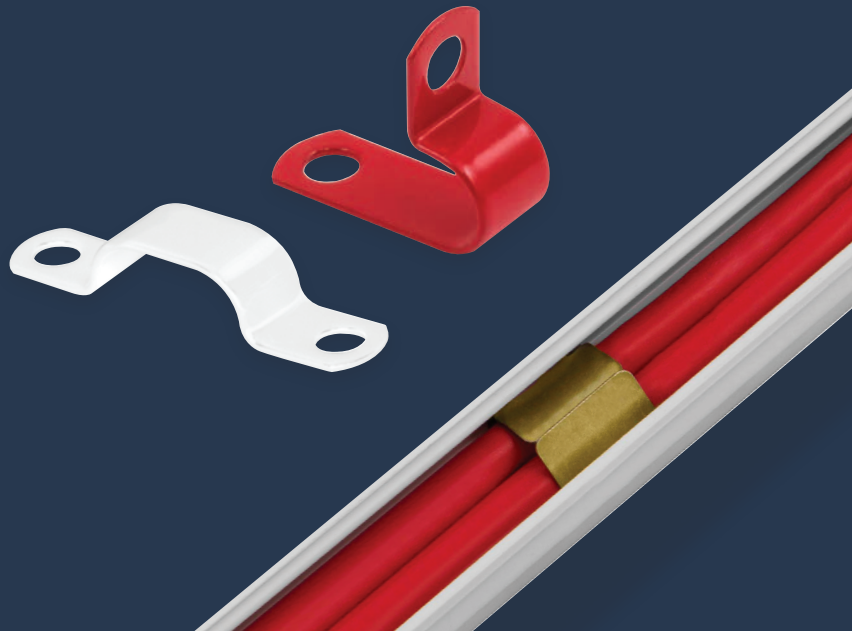

Q-CRIMP®

Explore our extensive range of cable management consumables. All our products are manufactured under stringent quality control systems and are fully compliant with the very latest industry regulations.



Complete the Installation...

Bluetooth DIN Rail Time Switches

Bluetooth is a wireless communication protocol that allows programming of the switch using the free APP available on Android and IOS smart phones and tablets. This works the same way as contactless bank cards, oyster travel cards and mobile payment systems. The program is setup on the APP and transfers to the switch when the smart device is held in close proximity.

NFC DIN Rail Time Switches

NFC (Near Field Communication) is a wireless communication protocol that allows you to program the switch using the free Sangamo Connect app on an Android NFC Smart phone.

This works the same way as contactless bank cards, oyster travel cards and mobile payment systems. You set the program up on the app and hold the phone next to the switch to read, write or transfer programming times.

DIN Rail Time Switches

All Sangamo's DIN Rail mountable time switches are designed for 35mm "Top Hat" rail. Switches come in 1, 2 or 4 modules, each module is 17.5mm wide, which fits the required width in the DIN enclosure.

Using the 25195 USB Hub and Easy Vue software or 25196 USB Hub with bluetooth and connect app programs can be transferred to a 25193 data key and then to one or multiple switches. 1 module switches do not require a Data Key as the fascia can be removed and slotted into the Hub directly.



Bluetooth DIN Rail Time Switches



SC2811PRO4

Standard Bluetooth 2 Module 1 Channel, 7 Day, 100 Operations

SC2813PRO4

Astro Bluetooth 2 Module 1 Channel, 7 Day, 100 Operations

SC2823PRO4

Astro Bluetooth 2 Module 2 Channel, 7 Day, 100 Operations

NFC DIN Rail Time Switches



72113NFC

Standard NFC 2 Module 1 Channel, 7 Day, 56 Operations

72102NFC

Astro NFC Module 1 Channel, 24HR Timer, 4 Operations

72103NFC

Astro NFC 2 Module 1 Channel, 7 Day, 56 Operations

DIN RAIL TIME SWITCHES



71111

Standard 1 Module 1 Channel, 7 Day, 46 Operations

72112

Standard 2 Module 1 Channel, 7 Day, 46 Operations

25162

Standard 2 Module 1 Channel, Yearly, 300 Operations

26404

Standard 4 Module 4 Channel, 7 Day, 300 Operations

11002

Standard 1 Module 24HR Timer

71101

Astro 1 Module 1 Channel, 7 Day, 60 Operations

72101

Astro 2 Module 1 Channel, 7 Day, 60 Operations

72201

Astro 2 Module 2 Channel, 7 Day, 60 Operations



Terminal Layouts...

8 Way - Neutral & Earth Terminal Configuration



10 Way - Neutral & Earth Terminal Configuration



12 Way - Neutral & Earth Terminal Configuration



14 Way - Neutral & Earth Terminal Configuration



16 Way - Neutral & Earth Terminal Configuration



18 Way - Neutral & Earth Terminal Configuration



22 Way - Neutral & Earth Terminal Configuration



Switch-Disconnecter Units

A range of Elucian Metal Consumer Units furnished with a 100A Mains Switch.



*Example shown - CUEB12MS10

Available in...

CUEB8MS6

8 Way Unit with 100A Mains Switch (6 Free Ways)

222 (W) x 260 (H) x 115 (D)

CUEB10MS8

10 Way Unit with 100A Mains Switch (8 Free Ways)

258 (W) x 260 (H) x 115 (D)

CUEB12MS10

12 Way Unit with 100A Mains Switch (10 Free Ways)

294 (W) x 260 (H) x 115 (D)

CUEB14MS12

14 Way Unit with 100A Mains Switch (12 Free Ways)

330 (W) x 260 (H) x 115 (D)

CUEB16MS14

16 Way Unit with 100A Mains Switch (14 Free Ways)

366 (W) x 260 (H) x 115 (D)

CUEB18MS16

18 Way Unit with 100A Mains Switch (16 Free Ways)

402 (W) x 260 (H) x 115 (D)

CUEB22MS20

22 Way Unit with 100A Mains Switch (20 Free Ways)

474 (W) x 260 (H) x 115 (D)



Terminal Layouts...

10 Way - Neutral & Earth Terminal Configuration



12 Way - Neutral & Earth Terminal Configuration



14 Way - Neutral & Earth Terminal Configuration



16 Way - Neutral & Earth Terminal Configuration



18 Way - Neutral & Earth Terminal Configuration



22 Way - Neutral & Earth Terminal Configuration



Switch-Disconnecter Units Including Surge Protection

A range of Elucian Metal Consumer Units furnished with a 100A Mains Switch and a 2 Pole Type 2 275Uc (V~) 40kA SPD.



Straight
Mains Board



100A
Mains
Switch Fitted



Tail Clamp
Pre-Installed



SPD
SPD Fitted

*Example shown - CUEB18MSSP15

Available in...

CUEB10MSSP7

10 Way Unit with 100A Mains Switch & SPD (7 Free Ways)

258 (W) x 260 (H) x 115 (D)

CUEB12MSSP9

12 Way Unit with 100A Mains Switch & SPD (9 Free Ways)

294 (W) x 260 (H) x 115 (D)

CUEB14MSSP11

14 Way Unit with 100A Mains Switch & SPD (11 Free Ways)

330 (W) x 260 (H) x 115 (D)

CUEB16MSSP13

16 Way Unit with 100A Mains Switch & SPD (13 Free Ways)

366 (W) x 260 (H) x 115 (D)

CUEB18MSSP15

18 Way Unit with 100A Mains Switch & SPD (15 Free Ways)

402 (W) x 260 (H) x 115 (D)

CUEB22MSSP19

22 Way Unit with 100A Mains Switch & SPD (19 Free Ways)

474 (W) x 260 (H) x 115 (D)



Terminal Layouts...

14 Way - Neutral & Earth Terminal Configuration

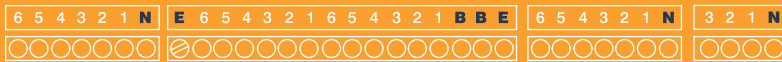

16 Way - Neutral & Earth Terminal Configuration

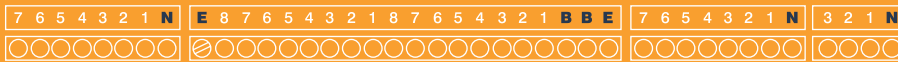

18 Way - Neutral & Earth Terminal Configuration



22 Way - Neutral & Earth Terminal Configuration



Split Load Units

A range of Elucian Metal Consumer Units furnished with a 100A Mains Switch and 2 x 80A Type A RCDs.



Split Load Board



100A Mains Switch Fitted



Tail Clamp Pre-Installed



RCD Fitted



*Example shown - CUEB18MSRCD12

Available in...

CUEB14MSRCD8

14 Way Unit with 100A Mains Switch + 2 x 80A 30mA RCD (4+4 Free Ways)

330 (W) x 260 (H) x 115 (D)

CUEB16MSRCD10

16 Way Unit with 100A Mains Switch + 2 x 80A 30mA RCD (5+5 Free Ways)

366 (W) x 260 (H) x 115 (D)

CUEB18MSRCD12

18 Way Unit with 100A Mains Switch + 2 x 80A 30mA RCD (6+6 Free Ways)

402 (W) x 260 (H) x 115 (D)

CUEB22MSRCD16

22 Way Unit with 100A Mains Switch + 2 x 80A 30mA RCD (8+8 Free Ways)

474 (W) x 260 (H) x 115 (D)



Terminal Layouts...

14 Way - Neutral & Earth Terminal Configuration



16 Way - Neutral & Earth Terminal Configuration

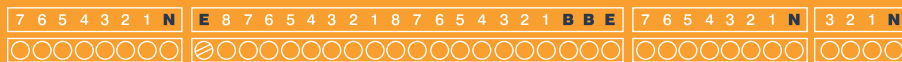

18 Way - Neutral & Earth Terminal Configuration

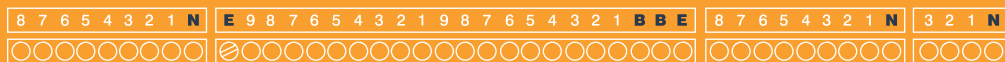

22 Way - Neutral & Earth Terminal Configuration



Split Load Units Including Surge Protection

A range of Elucian Metal Consumer Units furnished with a 100A Mains Switch, 2 x 80A Type A RCDs and a 2 Pole Type 2 275Uc (V~) 40kA SPD.



Split
Load Board



100A
Mains
Switch Fitted



Tail Clamp
Pre-Installed



RCD
Fitted



SPD
Fitted

*Example shown - CUEB14MSRCDSP6

Available in...

CUEB14MSRCDSP6

14 Way Unit with 100A Mains Switch + 2 x 80A 30mA RCD
+ 2 Pole SPD (3+3 Free Ways)

330 (W) x 260 (H) x 115 (D)

CUEB16MSRCDSP8

16 Way Unit with 100A Mains Switch + 2 x 80A 30mA RCD
+ 2 Pole SPD (4+4 Free Ways)

366 (W) x 260 (H) x 115 (D)

CUEB18MSRCDSP10

18 Way Unit with 100A Mains Switch + 2 x 80A 30mA RCD
+ 2 Pole SPD (5+5 Free Ways)

402 (W) x 260 (H) x 115 (D)

CUEB22MSRCDSP14

22 Way Unit with 100A Mains Switch + 2 x 80A 30mA RCD
+ 2 Pole SPD (7+7 Free Ways)

474 (W) x 260 (H) x 115 (D)



Terminal Layouts...

14 Way - Neutral & Earth Terminal Configuration

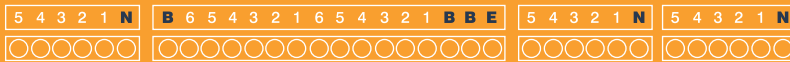

16 Way - Neutral & Earth Terminal Configuration

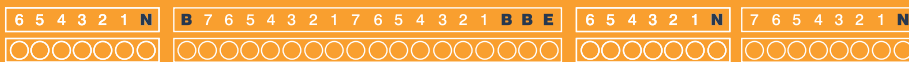

18 Way - Neutral & Earth Terminal Configuration



22 Way - Neutral & Earth Terminal Configuration



Combination Units (High Integrity)

A range of High Integrity Elucian Metal Consumer Units furnished with a 100A Mains Switch and 2 x 80A Type A RCDs.



*Example shown - CUEHIB18MSRCD12

Available in...

CUEHIB14MSRCD8

14 Way Unit with 100A Mains Switch + 2 x 80A RCD (8 Free Ways)

330 (W) x 260 (H) x 115 (D)

CUEHIB16MSRCD10

16 Way Unit with 100A Mains Switch + 2 x 80A RCD (10 Free Ways)

366 (W) x 260 (H) x 115 (D)

CUEHIB18MSRCD12

18 Way Unit with 100A Mains Switch + 2 x 80A RCD (12 Free Ways)

402 (W) x 260 (H) x 115 (D)

CUEHIB22MSRCD16

22 Way Unit with 100A Mains Switch + 2 x 80A RCD (16 Free Ways)

474 (W) x 260 (H) x 115 (D)



Terminal Layouts...

14 Way - Neutral & Earth Terminal Configuration



16 Way - Neutral & Earth Terminal Configuration



18 Way - Neutral & Earth Terminal Configuration



Combination Units (High Integrity) Including Surge Protection

A range of High Integrity Elucian Metal Consumer Units furnished with a 100A Mains Switch, 2 x 80A Type A RCDs and a 2 Pole Type 2 275Uc (V~) 40kA SPD.



*Example shown - CUEHIB18MSRCDSP10

Available in...

CUEHIB14MSRCDSP6

14 Way Unit with 100A Mains Switch + 2 x 80A RCD & SPD (6 Free Ways)

330 (W) x 260 (H) x 115 (D)

CUEHIB16MSRCDSP8

16 Way Unit with 100A Mains Switch + 2 x 80A RCD & SPD (8 Free Ways)

366 (W) x 260 (H) x 115 (D)

CUEHIB18MSRCDSP10

18 Way Unit with 100A Mains Switch + 2 x 80A RCD & SPD (10 Free Ways)

402 (W) x 260 (H) x 115 (D)

CUEHIB22MSRCDSP14

22 Way Unit with 100A Mains Switch + 2 x 80A RCD & SPD (14 Free Ways)

474 (W) x 260 (H) x 115 (D)



Terminal Layouts...

5 Way - Neutral & Earth Terminal Configuration

5	4	E	3	2	1	E	5	4	3	2	1	N
○	○	○	○	○	○	○	○	○	○	○	○	○

Mini Units (Garage)

A range of Elucian Metal Consumer Units ideal for garage installations. Furnished with either a 63A or 80A Type A RCD.



*Example shown - GUEB563RCD3

Available in...

.....
GUEB563RCD3

5 Way Unit with 63A 30mA RCD (3 Free Ways)

.....
168 (W) x 260 (H) x 115 (D)
.....

.....
GUEB580RCD3

5 Way Unit with 80A 30mA RCD (3 Free Ways)

.....
168 (W) x 260 (H) x 115 (D)
.....



Terminal Layouts...

5 Way - Neutral & Earth Terminal Configuration



6 Way - Neutral & Earth Terminal Configuration



8 Way - Neutral & Earth Terminal Configuration



10 Way - Neutral & Earth Terminal Configuration



12 Way - Neutral & Earth Terminal Configuration



14 Way - Neutral & Earth Terminal Configuration



16 Way - Neutral & Earth Terminal Configuration



18 Way - Neutral & Earth Terminal Configuration



22 Way - Neutral & Earth Terminal Configuration



Unpopulated Consumer Units

A range of unpopulated Elucian Metal Consumer Units ideal for those projects that need custom configuration without limitations on module placement.



*Example shown - CUEB16

Available in...

GUEB5

5 Way Unpopulated Metal Garage Unit

168 (W) x 260 (H) x 115 (D)

CUEB6

6 Way Unpopulated Metal Consumer Unit

185 (W) x 260 (H) x 115 (D)

CUEB8

8 Way Unpopulated Metal Consumer Unit

222 (W) x 260 (H) x 115 (D)

CUEB10

10 Way Unpopulated Metal Consumer Unit

258 (W) x 260 (H) x 115 (D)

CUEB12

12 Way Unpopulated Metal Consumer Unit

294 (W) x 260 (H) x 115 (D)

CUEB14

14 Way Unpopulated Metal Consumer Unit

330 (W) x 260 (H) x 115 (D)

CUEB16

16 Way Unpopulated Metal Consumer Unit

366 (W) x 260 (H) x 115 (D)

CUEB18

18 Way Unpopulated Metal Consumer Unit

402 (W) x 260 (H) x 115 (D)

CUEB22

22 Way Unpopulated Metal Consumer Unit

474 (W) x 260 (H) x 115 (D)

Keeping you
in Charge...

 elucian



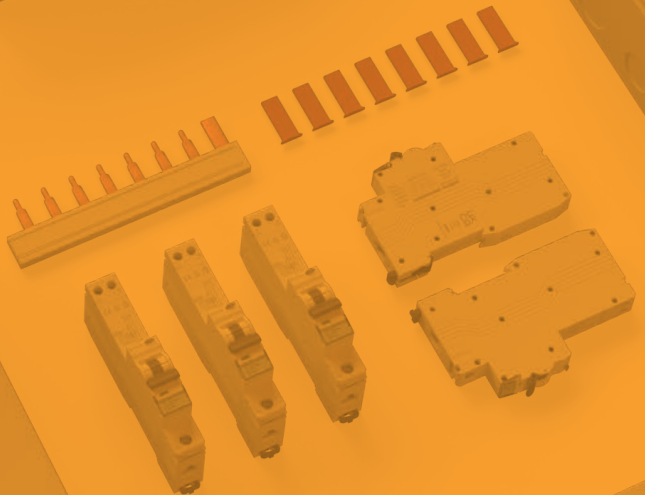
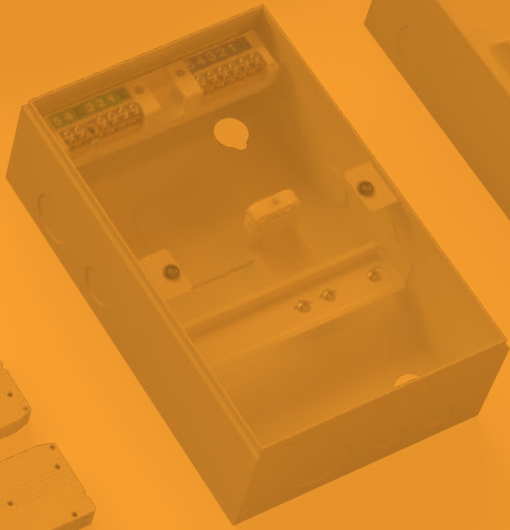

Protective Devices

Our Elucian range of Protective Devices are easy to install, suitable for residential and light commercial environments, they provide protection against earth faults to ensure people's safety against electrocution and fires.

 elucian



02

Features & Benefits...

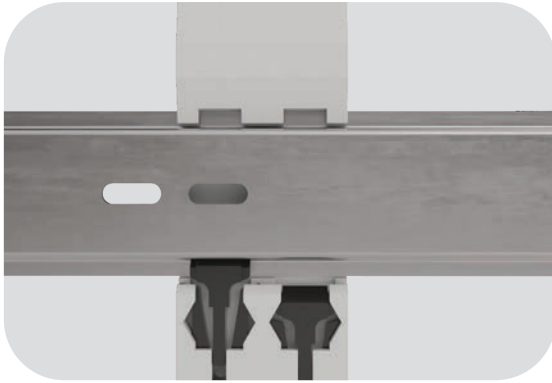

Clip in Devices

The Elucian Protective Devices simply click onto the DIN Rail and can be secured with this locking mechanism. This means work can be carried out quicker and without dealing with tight spaces.



Lock Off Capabilities

Lockout devices (available at Unicrimp®) are designed to attach to the moving part of the protective device, usually a switch toggle (rocker switch) which moves from the on to off position. This ensures the switch cannot be switched back on while work is being carried out.



Clear Indication

Each protective device has clear and visible trip indication along with clear product information which is easily visible whatever the switch position.









3 Year Product Warranty

We take pride in leading the market and our 3 year warranty offers the best peace of mind available as standard today. It reflects the confidence we have in our products and the benefit of years of continuous engineering improvement.

RCBO Devices

1 Pole + Neutral True 6kA B Curve & C Curve 30mA Trip RCBOs

 1 Pole + Neutral	 30mA Trip Current	 6kA True 6kA
 Type A	 Large Terminal Capacity	 3YR 3 Year Warranty

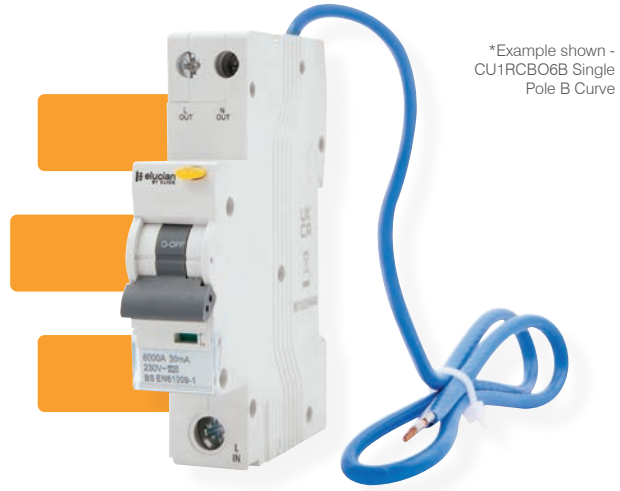

*Example shown - CU1RCBO6B Single Pole B Curve

RCBO's Type A Single Pole B Curve

CU1RCBO6B

6A 30mA B Curve True 6kA RCBO

CU1RCBO10B

10A 30mA B Curve True 6kA RCBO

CU1RCBO16B

16A 30mA B Curve True 6kA RCBO

CU1RCBO20B

20A 30mA B Curve True 6kA RCBO

CU1RCBO25B

25A 30mA B Curve True 6kA RCBO

CU1RCBO32B

32A 30mA B Curve True 6kA RCBO

CU1RCBO40B

40A 30mA B Curve True 6kA RCBO

RCBO's Type A Single Pole C Curve

CU1RCBO6C

6A 30mA C Curve True 6kA RCBO

CU1RCBO10C

10A 30mA C Curve True 6kA RCBO

CU1RCBO16C

16A 30mA C Curve True 6kA RCBO

CU1RCBO20C

20A 30mA C Curve True 6kA RCBO

CU1RCBO25C

25A 30mA C Curve True 6kA RCBO

CU1RCBO32C

32A 30mA C Curve True 6kA RCBO

CU1RCBO40C

40A 30mA C Curve True 6kA RCBO

SPD's

2 Pole 40kA Type 2 18mm Surge Protection Device With Tails

 Double Pole	 <25ns Response Time	 <1.5kV Protection Level (UP)
 40kA Max Discharge Current	 3YR 3 Year Warranty	 Large Terminal Capacity

CU1SPD275T

40kA 275Uc (V~) 2 Pole Type 2 SPD with Tails



AFDD & RCBO

1 Pole True 6kA B & C Curve AFDD & RCBO

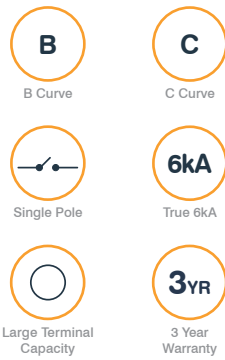

Type B Curve AFDD & RCBO

CU1AFDD6B

1 Pole True 6kA B Curve 6A AFDD & RCBO 30mA

CU1AFDD10B

1 Pole True 6kA B Curve 10A AFDD & RCBO 30mA

CU1AFDD16B

1 Pole True 6kA B Curve 16A AFDD & RCBO 30mA

CU1AFDD20B

1 Pole True 6kA B Curve 20A AFDD & RCBO 30mA

CU1AFDD32B

1 Pole True 6kA B Curve 32A AFDD & RCBO 30mA

CU1AFDD40B

1 Pole True 6kA B Curve 40A AFDD & RCBO 30mA

Type C Curve AFDD & RCBO

CU1AFDD6C

1 Pole True 6kA C Curve 6A AFDD & RCBO 30mA

CU1AFDD10C

1 Pole True 6kA C Curve 10A AFDD & RCBO 30mA

CU1AFDD16C

1 Pole True 6kA C Curve 16A AFDD & RCBO 30mA

CU1AFDD20C

1 Pole True 6kA C Curve 20A AFDD & RCBO 30mA

CU1AFDD32C

1 Pole True 6kA C Curve 32A AFDD & RCBO 30mA

CU1AFDD40C

1 Pole True 6kA C Curve 40A AFDD & RCBO 30mA

Contactor NONC Devices

20A, 25A, 40A or 63A Modular Contactors



3 Year
Warranty



Normally
Open



Large Terminal
Capacity



Normally
Closed



2 Pole 20A Modular Contactors (1 Module)

MC20220

2 Pole 1 Module 20A Contactor, 2 x Normally Open Contacts

MC20202

2 Pole 1 Module 20A Contactor, 2 x Normally Closed Contacts

MC20211

2 Pole 1 Module 20A Contactor, 1 x Normally Open, 1 x Normally Closed Contacts

4 Pole 40A Modular Contactors (3 Module)

MC40440

4 Pole 3 Module 40A Contactor, 4 x Normally Open Contacts

MC40404

4 Pole 3 Module 40A Contactor, 4 x Normally Closed Contacts

MC40422

4 Pole 3 Module 40A Contactor, 2 x Normally Open, 2 x Normally Closed Contacts

MC40431

4 Pole 3 Module 40A Contactor, 3 x Normally Open, 1 x Normally Closed Contacts

4 Pole 25A Modular Contactors (2 Module)

MC25440

4 Pole 2 Module 25A Contactor, 4 x Normally Open Contacts

MC25404

4 Pole 2 Module 25A Contactor, 4 x Normally Closed Contacts

MC25422

4 Pole 2 Module 25A Contactor, 2 x Normally Open, 2 x Normally Closed Contacts

MC25431

4 Pole 2 Module 25A Contactor, 3 x Normally Open, 1 x Normally Closed Contacts

4 Pole 63A Modular Contactors (3 Module)

MC63440

4 Pole 3 Module 63A Contactor, 4 x Normally Open Contacts

MC63404

4 Pole 3 Module 63A Contactor, 4 x Normally Closed Contacts

MC63422

4 Pole 3 Module 63A Contactor, 2 x Normally Open, 2 x Normally Closed Contacts

MC63431

4 Pole 3 Module 63A Contactor, 3 x Normally Open, 1 x Normally Closed Contacts

RCD's



1 Pole + Neutral



A
Type A



S
Type S



Large Terminal Capacity



3YR
3 Year Warranty



*Example shown - CU2RCD80A

2 Pole 30mA Residual Circuit Devices

CU2RCD63A

63A 30mA 2 Pole RCD

CU2RCD80A

80A 30mA 2 Pole RCD

CU2RCD100A

100A 30mA 2 Pole RCD

Time Delay RCD's

CU2RCDTD63A

63A 100mA 2 Pole Time Delay RCD

CU2RCDTD80A

80A 100mA 2 Pole Time Delay RCD

CU2RCDTD100A

100A 100mA 2 Pole Time Delay RCD

RCBO Devices

Double Pole 2 Module True 6kA B Curve & C Curve 30mA Trip RCBOs



A
Type A



Large Terminal Capacity (mm²)



6kA
True 6kA



30mA
Trip Current



Double Pole



RCBO's Type A 2 Module Double Pole B Curve

CU2RCBO45B

45A 30mA B Curve True 6kA RCBO

CU2RCBO50B

50A 30mA B Curve True 6kA RCBO

CU2RCBO63B

63A 30mA B Curve True 6kA RCBO

RCBO's Type A 2 Module Double Pole C Curve

CU2RCBO45C

45A 30mA C Curve True 6kA RCBO

CU2RCBO50C

50A 30mA C Curve True 6kA RCBO

CU2RCBO63C

63A 30mA C Curve True 6kA RCBO

MCB's Single Pole

1 Pole, True 6kA B Curve & C Curve MCB Devices.

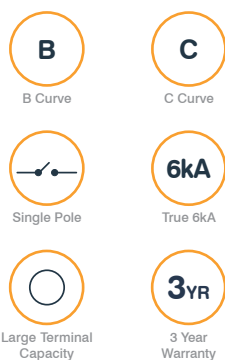

Available in...

CU1MCB6B

6A B Curve True 6kA MCB

CU1MCB10B

10A B Curve True 6kA MCB

CU1MCB16B

16A B Curve True 6kA MCB

CU1MCB20B

20A B Curve True 6kA MCB

CU1MCB25B

25A B Curve True 6kA MCB

CU1MCB32B

32A B Curve True 6kA MCB

CU1MCB40B

40A B Curve True 6kA MCB

CU1MCB50B

50A B Curve True 6kA MCB

CU1MCB63B

63A B Curve True 6kA MCB

CU1MCB6C

6A C Curve True 6kA MCB

CU1MCB10C

10A C Curve True 6kA MCB

CU1MCB16C

16A C Curve True 6kA MCB

CU1MCB20C

20A C Curve True 6kA MCB

CU1MCB25C

25A C Curve True 6kA MCB

CU1MCB32C

32A C Curve True 6kA MCB

CU1MCB40C

40A C Curve True 6kA MCB

CU1MCB50C

50A C Curve True 6kA MCB

CU1MCB63C

63A C Curve True 6kA MCB

Mains Switch-Disconnecter

2 Pole 100A Mains Isolator Switch.



Double Pole



100A Rated



Large Terminal Capacity



3 Year Warranty

Available in...

CU2MS100

100A 2 Pole Disconnecter-Switch



Blank Modules

Single way Din Rail Blank Module.



3 Year Warranty

CU1BLANK

Single Way Din Rail Blank Module



Energy Meters

100A Single Phase Modbus Multifunction Meter



Available in...

CU2EMID

100A Single Phase Modbus Multifunction Meter



Fused Main Switch

80A & 100A Fused Main Switches



Available in...

DB700

80A Fused Main Switch (80A HRC Fuse Fitted)

DB701

80A Fused Main Switch (80A HRC Fuse Fitted) - Lockable

DB750

100A Fused Main Switch (80A HRC Fuse Fitted)

DB751

100A Fused Main Switch (80A HRC Fuse Fitted) - Lockable

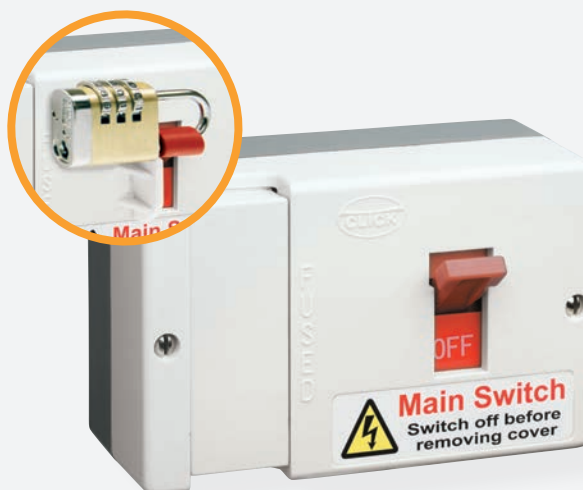

Elucian

Accessories...

Fused Main Switch Accessories

DB790	Metal Enclosure for Fused Main Switch (DB700/701) *Suitable for DB700/701 80A fused main switch
DB791	Metal Enclosure for Fused Main Switch (DB750/751) *Suitable for DB701/751 100A fused main switch
DB981	Elongated Cable Shroud (Packaged Individually) *Enables surface and rear entry cable access *Suitable for 35mm ² cables



Terminal Bars

CUTB4	4 Way Terminal Bar
CUTB6	6 Way Terminal Bar
CUTB7	7 Way Terminal Bar
CUTB8	8 Way Terminal Bar
CUTB9	9 Way Terminal Bar
CUTB10	10 Way Terminal Bar
CUTB12	12 Way Terminal Bar
CUTB15	15 Way Terminal Bar
CUTB16	16 Way Terminal Bar
CUTB17	17 Way Terminal Bar
CUTB18	18 Way Terminal Bar
CUTB19	19 Way Terminal Bar
CUTB20	20 Way Terminal Bar
CUTB22	22 Way Terminal Bar
CUTB23	23 Way Terminal Bar
CUTB26	26 Way Terminal Bar
CUTBSC	Terminal Bar Support Clip & Screws (PK5)
CUTBSCSL	Split Load Terminal Bar Support Clip & Screws (PK 5)

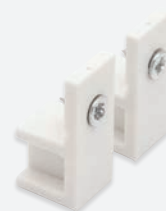

*All accessories are for use on Elucian Consumer Units only and are not suitable for Consumer Unit conversions.

Busbar & Cover Sets

CUBUS3 3 Way Busbar & Cover Set

CUBUS4 4 Way Busbar & Cover Set

CUBUS5 5 Way Busbar & Cover Set

CUBUS6 6 Way Busbar & Cover Set

CUBUS7 7 Way Busbar & Cover Set

CUBUS8 8 Way Busbar & Cover Set

CUBUS12 12 Way Busbar & Cover Set

CUBUS20 20 Way Busbar & Cover Set

CUCAP Busbar Caps (PK 10)

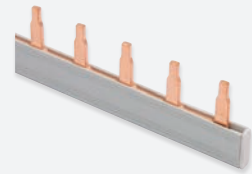
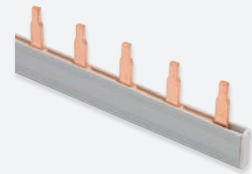

DIN Rails

CUDR10 10 Way DIN Rail

CUDR12 12 Way DIN Rail

CUDR14 14 Way DIN Rail

CUDR16 16 Way DIN Rail

CUDR18 18 Way DIN Rail

CUDR22 22 Way DIN Rail



Elucian

Accessories...

SPD Cartridge

CU1SPDC275	275V~ 40kA 18mm SPD Cartridge	
CU2SPDC275	275V~ 40kA 36mm SPD Cartridge	*Replacement for both live and neutral sides



Link Cables

CUCNL210	Neutral Link Cable (210mm)
CUCNL285	Neutral Link Cable (285mm)
CUCNL325	Neutral Link Cable (325mm)
CUCLL	Combined Live Link Cable (285mm & 355mm)



Grommet Strip

CUGS1	500mm Grommet Strip (PK 3)
--------------	----------------------------



*All accessories are for use on Elucian Consumer Units only and are not suitable for Consumer Unit conversions.

Mains Cable Clamp Components

CUCLAMP Mains Cable Clamp & Screw

CUPLATE Mains Cable Clamp Plate



Retrofit Locking Device

CUELOCK Retrofit Locking Device

*Can be installed on the left or right of the enclosure.
*Padlock not supplied.



Adhesive Labels

CULAB1 Set of Adhesive Labels



Elucian Accessories...

*All accessories are for use on Elucian Consumer Units only and are not suitable for Consumer Unit conversions.

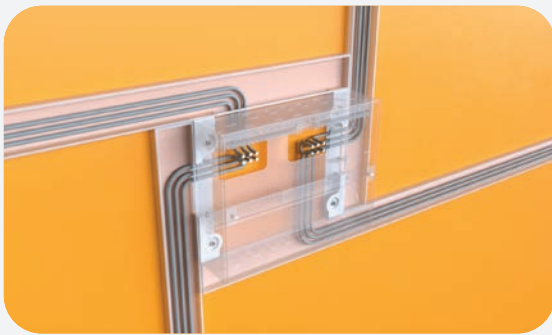

Pattress Mount

.....
CUEBPM

Consumer Unit Pattress Mount
.....



Flush Lid

.....
CUEB18FL

Flush Lid (18 Way Consumer Units)
.....



Cable Entry Plate

.....
CUCEPL

Knockout Cable Entry Plate - Large (PK 5)
.....

.....
CUCEPS

Knockout Cable Entry Plate - Small (PK 5)
.....

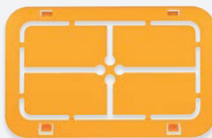

Recess Frames

.....
CUEBRF16

16 Way Consumer Unit Recessed Frame
.....

.....
CUEBRF18

18 Way Consumer Unit Recessed Frame
.....

.....
CUEBRF22

22 Way Consumer Unit Recessed Frame
.....





More from Scolmore® Group...

Click® Wiring Accessories

Scolmore® International is one of the UK's leading manufacturers of electrical accessories.

The company is proud to be a British-based, family-run business with an international reputation for quality, innovation and exemplary customer service.

From our Head Office in the Midlands, we design, develop and manufacture an ever expanding product range for distribution throughout the UK and worldwide.

The Click® Wiring Accessories range remains the number one choice of electricians and contractors who value the flexibility of the modular based range, as well as the one-stop solution that the comprehensive offer allows.

Scolmore House
Mariner, Lichfield Road Industrial Estate,
Tamworth, Staffordshire,
B79 7UL, UK

+44 (0) 1827 63454
sales@scolmore.com
www.scolmore.com



Unicrimp® Cable Accessories

Unicrimp® brings to the electrical contracting industry a comprehensive range of cable accessory products.

All products within the Q-Crimp® range are manufactured under stringent quality control systems and are fully compliant with the very latest industry regulations.

The range includes cable ties, crimp terminals, PVC tape, copper tube terminals, cable clips, and brass and nylon glands. Also available under the Q-Fire brand are products to help you keep up to date with all the latest fire regulations.

Located close to the Scolmore Group Headquarters in the Midlands, the Unicrimp® distribution centre is ideally located to supply to all areas of the UK.

Scolmore House
Mariner, Lichfield Road Industrial Estate,
Tamworth, Staffordshire,
B79 7UL, UK

+44 (0) 1827 300600
sales@unicrimp.com
www.unicrimp.com



Lighting Solutions from Ovia®

Ovia® is an independent lighting brand established by Scolmore® in 2019.

Ovia® brings to market an extensive range of high quality, competitively-priced lighting and lighting control products that offer easy to install solutions across a variety of applications - commercial, industrial, domestic, utility, amenity, floodlighting and emergency lighting.

The comprehensive range was developed on the back of extensive research with customers and contractors and satisfies the requirements of an evolving lighting sector which has been transformed in recent years.

Scolmore House
Mariner, Lichfield Road Industrial Estate,
Tamworth, Staffordshire,
B79 7UL, UK

+44 (0) 1827 300640
sales@oviaUK.com
www.oviauk.com



ESP® Fire Safety and Security

ESP® has been developing and supplying security related products to the UK electrical industry for more than 20 years.

As a leading safety and security product specialist, the company offers a comprehensive range of electronic security and fire detection solutions to meet the requirements of installers and contractors.

At ESP® we create simple, smart solutions for a safer and more comfortable home. Discover a whole range of smart home products. From smart alarm kits, smart cameras, smart sensors and smart door bells, all working together to make your home smarter and safer.

Elite Security Products
Unit 7, Target Park,
Shawbank Road, Lakeside,
Redditch B98 8YN

+44 (0) 1527 515150
sales@espuk.com
www.espuk.com



United Kingdom



Scolmore House, Mariner,
Lichfield Road Industrial Estate,
Tamworth, Staffordshire, B79 7UL

+44 (0) 1827 63454
sales@scolmore.com
www.scolmore.com



Southern Ireland



18 Corrig Road,
Sandyford Industrial Estate,
Dublin, D18 WW79, Ireland

+353 (1) 2811 122
sales@clicklitehouse.ie
www.clicklitehouse.ie



Dubai, UAE



Lake Central Tower,
Office 1803, Business Bay,
Dubai, UAE

UAE Office: +971 4589 6552
sales@scolmoreme.com
www.scolmoreme.com

